



*Best wishes for you and your family and friends from the K5600 team.*

*2011 was not a bad year but already the perspective of the first semester of 2012 looks poor. We hear that we are going into recession and the word "crisis" has been used again by politicians and economists and will no doubt be an excuse for not spending.*

*There was a time when the movie business was not subject to the consequences of an economical crisis. The reason was that people went to the movies to divert their minds from the daily routine of misfortune. What has changed since? Expansion of TV channels, DVD, VOD...? Not only. Our small business of image production has been absorbed (infested) by financial conglomerates who care more about spreadsheets than passion and pride.*

*We are losing a lot in the process: No more respect for people, equipment and customers.*

*We are, whether it is big productions or corporate films, in a business model for which there is no model. Our business is about making a prototype, a unique (Master) piece. In our world of professional image production, we manufacture cameras, lenses, lights, grip in quantities of hundreds not hundreds of thousands. Production of images is all about people: Creative people, technical people, but above all MOTIVATED and PASSIONATE people. We are going through a phase of changes and technical progress but this is not a bad thing. Progress is what we make it, we have to learn to work with it: "adapt or disperse"*

*May your motivation remain intact and may your passion grow in 2012.*

## CHIUN-KAI SHIH



"I really enjoy working with the K5600 HMI lighting system, the light is very unique and easy to work with, it's a whole new experience from strobe lights, I would love to see more fashion photographers work with this amazing HMI lighting system soon." **Chiun-Kai Shih**, Photographer

## MICHAEL SOO



"I am using the Jokers for commercial or product photography when precision is one of the requirements. Nothing like seeing what you're getting, to create the perfect shine on diamonds. The photo above was done using K5600 Joker 400 and 800 with Joker Crossover Adapter and Beauty Dish for Apple products in San Francisco's MacWorld." Michael Soo Photographer.

### CROSSOVER ADAPTER



Motion requires continuous light, and digital loves daylight. Our 200, 400 & 800W Jokers deliver flicker-free daylight to capture both still and video--without re-lighting. Jokers look and perform just like flash heads. Add the Crossover Adapter and they fit into the reflectors you've been using for years. You can easily branch out to cinema-style lighting with our Beamers, Softubes and many other light shapers.

Jokers were chosen Lighting System of the Year by **Photo District News** Editor Dan Havlik. Dan writes "I get to test drive a lot of high-quality gear for PDN Magazine but every once in a while I go behind the wheels of a Rolls Royce. In the case of a continuous light source for location or studio work, K 5600 Lighting is certainly in that class."

## News from Scandinavia:



**Wallin & Vallin Ljus, Dagsljus** and **Ljud & Bildmedia** all provided equipment on the second screen version of the famous best-seller Trilogy by Stieg Larsson: *Millenium*. *Jokers* were used on locations.

Famous Swedish commercial DOP Fredrik Bäckar FSF started the film but was replaced by US cinematographer Jeff Cronenweth ASC. David Fincher and Jeff go back a long way. Jeff was already AC on *Se7en*, 2<sup>nd</sup> unit on *The Game* and did, as cinematographer, two of Fincher's most successful films: *Fight Club* and *The Social Network*.

**Fredrik** was replaced for artistic reasons. **Fincher** and him apparently did not share the same vision, but did share enough for **Frederick Bäckar** to have quite a few of his shots in the movie.

Note that this is a remake of the Swedish films shot in 2009 by Danish Cinematographer **Eric Kress**. **Kress** was the first Scandinavian Cinematographer to use the Alpha 18K from **Dagsljus** on *Arn: The Knight Templar* in 2007.

---

## News from the UK:



Stephen Murphy, Director of Photography, London, UK

"When I was asked to shoot the second season of "Shakespeare Unlocked" for the BBC and the Royal Shakespeare Company I knew I'd need a very particular kind of light to help me. I had seen the Joker Bugs at a demo by LCA lights in London and quickly realized that their compact size, powerful output and incredible range of accessories were the perfect combination. My creative remit was to deliver cinematic images while showcasing the existing lighting design at the Royal Shakespeare Theatre. With limited time and multiple lighting styles to work within I used Joker Bug 400 and 800's direct and with both Soft Tube and China ball accessories, mixing both hard and soft light in a variety of rigging situations. Their flexibility and ease of use kept us on schedule and the beautiful quality of light gave us results we are all extremely pleased with"

Contact for demos and information on K5600 products in the UK: LCA, Nick Shapley, Email: [nshapley@lcauk.com](mailto:nshapley@lcauk.com) Phone: +442088337600

---

## News from France:

**Bernard Cassan** has been using Joker Bugs and Alphas for years. We owe Bernard our Christmas/New year card. This was shot in November in Paris for the TV series *Julie Lescaut* which was aired for the first time in January 1992, exactly 20 years ago. Bernard has been a regular DP on the show which allows him to try all the different accessories to the Joker Bug and Alpha systems. He's a big fan of the Bug A Beam (with an 800 on the picture on the right). He likes the punch of the 800 and the precise beam control of the blades of the Source Four.

**Transpalux** provided the equipment.



## Focus on Camerimage:



The second year in Bydgoszcz and 19<sup>th</sup> edition of **Camerimage** ended on the 3<sup>rd</sup> of December with clement weather. This year we shared a booth with the famous zoom manufacturers **Angenieux** and **Transvideo** the pioneer in clever camera monitors. Together, we sponsored two events on the theme of 3D: A screening of **Wim Wenders Pina**, followed by The 3D Frame, a masterclass with **Denis Rouden AFC** and **Alain Derobe**, Stereographer who discussed their recent collaboration on the latest episode of the Asterix saga, *On Her Majesty's Service*. **Benjamin B** moderated the 90 minutes session which centered on 3D framing and camera movement, in front of an captivated audience of 160 people.



**John Seale ASC** was honored at Camerimage, becoming the 19<sup>th</sup> Director of Photography to receive Lifetime achievement award. We have a bit of history with John and his long time gaffer **Mo Flam**. They were the first to use the softtubes on *City Of Angels* for a bus scene. So when they went to Italy for *The Tourist*, Sebastien our man in Italy, showed them the Alpha 4K thinking it would be a good tool for their location shots in Venice. They took two and did not regret it as **John** mentioned : *"I thought the new 4k was a great light ...we are always wanting more power from the lamps ,and this one adds that much more ...especially on the night shoots on Anamorphic lenses ,where every foot candle counts and the 4k came up with the goods. Many thanks for supplying it to us for The Tourist. And Mo's comment was: "I liked the compact size of it and the sharp shadows using the clear lens. It was a very valuable tool in the right situation."*

## News of the Alpha 1600:

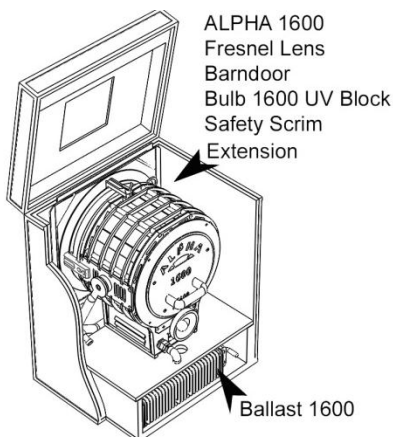

The first 20 units were gone within a week. You can try them:  
in **Sweden** @ *Ljud and Bildmedia, UrArt, Dagsjuls AB*  
in **Norway** @ *CHR Quartz Light*  
in **England** @ *Pixipixel*  
in **Belgium** @ *Eye-Lite*,  
in **Switzerland** @ *Visuals*  
in **France** @ *RVZ, Lumex, Vecteur M, Telline and Transpalux*).

The complete system fits in a flight case which can be wheeled around. Weight of the complete kit: 31 Kg.

**In January, you can benefit from a special launch price. Check it out.**

The Joker Bug 1600 will be available in February.



**Important notice:** If you want to share your experiences with our products, do not hesitate to contact us. You can find this Newsletter on our website as well as the previous ones that you can get in our "Download" section. VISIT US AT [www.k5600lighting.com](http://www.k5600lighting.com)